

Monthly Update

September 2018

September Club Meeting

When: Tuesday, Sep 18, 6:00pm

Where: Purple Woods Conservation Area – the repeater site

Sermon on the Mount – Corn Roast and BBQ! – Just like our June BBQ you need to come hungry, bring a lawn chair, an Amateur that is not a member of North Shore or someone who is interested in radio, and some finger food snacks to compliment the corn roast. Hey, if you have any unique items that you would like to show off throw them in the car and bring them out too.

If we could have a few people bring drinks that would be wonderful. If you can assist please let Laird VE3LKS know which of the following items you are able to bring by simply replying to the email that this newsletter came from. Ideally they would be in a cooler with ice but we can work around that if needed.

- ~~1 case of water~~ – taken care of
- 1 case of 24 – cola
- 1 case of 24 – mixed
- 2 case of 12 – diet pop

Excellent news! **Doug VA3DCE** has volunteered to help out and bring the snacks for the regular monthly meetings at White Cliffe. However, it would be great if someone else would volunteer to help lighten the load and be able to cover off for **Doug** if he is not available. It is an easy job as all you have to do is stop by a grocery store, pick up a couple packs of fresh cookies or the like, and bring them to the meeting. Just give the receipt to the treasurer and you will be reimbursed promptly.



APRS Ping of the Month

Joe VE3VGJ was heading north and right around Apsley he was hitting direct an APRS igate station, VE3PHC, in Sudbury.

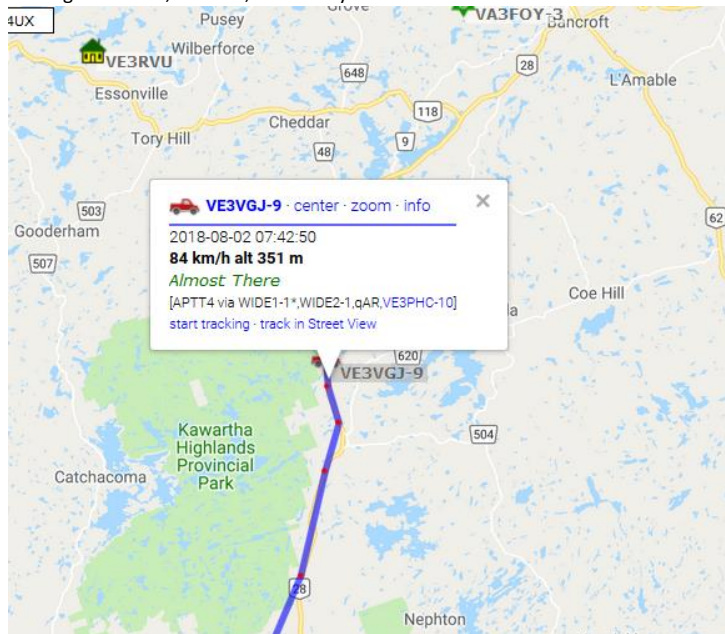

Repeater Update – Generator Issues

The repeater team discovered a few issues with the generator when we were doing some testing recently. The generator responds as it should when there is a power failure in that 15 seconds into a power failure the transfer switch will trip, the generator will start, and we will have power within about 45 seconds. What they did discover, though, was that the generator ran quite rough for the first minute or two and even when it warmed up it was not running as well as one would think and there was the distinct odor of propane signalling that the engine was probably running rich and not burning fuel properly. **Bob VE3HIX** went to work looking up info on the internet and quickly diagnosed that the valve clearance was not correct and was able to make those changes on a subsequent visit. The generator now starts up a lot easier and is running quite smoothly when operating. Another interesting find was that a branch of the tree, behind the generator building, had grown so much that it was preventing the buildings ventilation louvers from opening. A quick cut with a saw corrected that problem. Finally, after spending quite some time with his head in the generator case, working on the valve clearance issue, and becoming intimately familiar with how it was setup, **Bob** was spending some leisurely hours at home reading through the generator manual. He came across a diagram that made him question if the propane was connected to the wrong port on the generator. Our generator can be run on either propane or natural gas. After looking at diagrams he was suspicious that our current configuration may be hooked up incorrectly.

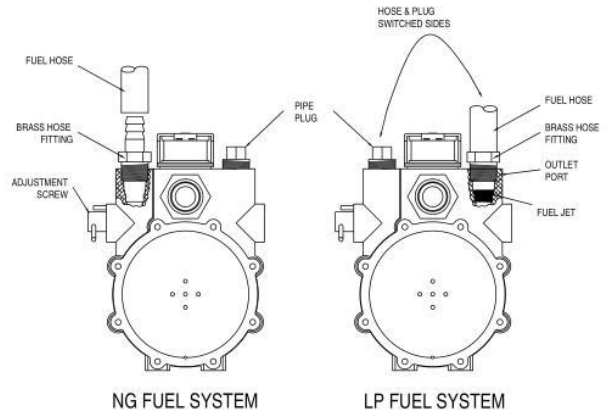

Well, all that meant is that we now had another excuse to meet at White Feather Farms for breakfast followed by another short trip up the hill to the repeater site. Here are **Bob's** words as to what was discovered.

"As we saw today, the gas regulator is actually connected properly on the Liquid Propane side, not the Natural Gas side. The actual regulator is installed backward, compared to the one in the book, to allow easy access to the Natural Gas adjustment (unused in our application). The attached illustration and photo show that the position is different, but the connection is correct. The generator now starts and runs smoothly, with no exhaust odor."

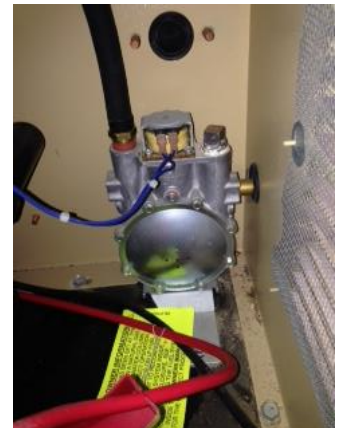

Excellent troubleshooting **Bob!** It just goes to show that even when you think you are wrong you are right!

W1AW Code Practice

Interested in learning code or brushing up on your code skills? W1AW has code practice on various bands as well as pre-recorded files that you can play on your computer any time. Check out the links below. Tnx, **Vic VE3JAR**, for this info.

Frequencies - <http://www.arrl.org/code-transmissions>

Operation schedule - <http://www.arrl.org/w1aw-operating-schedule>

Pre-recorded files - <http://www.arrl.org/code-practice-files>

Tuesday Night Rag Chew



Our Tuesday night rag chews are still continuing through the summer. This is not a formal net but rather a lively roundtable. Some can only stick around for a few minutes while others are there from start to finish. We never know what the topic de jour will be but someone always comes up with something. So, if you are available

between 1900 and 2000hr on Tuesdays pop onto OSH and join the conversation. As well, since this is a rag chew, and not a net, feel free to step in and moderate the group should one of the regulars not be there. All you have to do is jot down who is on and rotate through the list so that everyone gets a chance to participate.

Wednesday Night Face-to-Face

As well as the Tuesday night rag chew on the repeater there is quite a crew that meet at the Tim Horton's at King and Wilson at about 8pm every Wednesday. It actually gets quite crazy as we discuss all things radio, update our digital radios with the latest



Bob VE3HIX and Jeffrey VA3RTV

code plugs, show any new gadgets that have been acquired and generally have a good time. If you are in the area on Wednesday night, and have a few minutes to spare, we would definitely enjoy your company. This is open to anyone whether you are a member of the North Shore ARC or not. One Wednesday night **Bob VE3HIX** and **Jeffrey VA3RTV** brought in an SWR meter and SMA antenna mount and we tested the various handheld antennas for performance. It was surprising that some of the antennas on the low-cost radios actually beat out some of the big brands. See what you are missing if you are not coming out!?

Saturday Breakfast

If you are not tired of chatting or meeting up with club members during the week then you will be interested to know that there is a small group that meets on Saturday morning for breakfast at Johnny's Original Eatery. The restaurant is located in the plaza on the northwest corner of King and Thornton. Members and families usually start to arrive at about 8:30am.



As well, if there is work to be done at the repeater site on a Saturday morning, you will quite often find a large crowd at White Feather Farm, which opens at 8:30am, enjoying coffee, breakfast and maybe even one of their amazing, freshly baked, apple fritters. Just give a shout on the repeater between 8:00 and 8:20 to see if anyone is heading up that way and come and join us if we are. White Feather Farm is located at the corner of Simcoe St and Raglan Rd in Raglan.

QRM from the Shack



Time goes by too quickly. We are now at the end of the summer and it seems like it just barely began. For a time when there is typically not a lot of club activity this summer has been quite active, at least on the repeater side of things. Major kudos to the team that has been working on cleaning up the repeater and generator buildings, repairing, testing and modifying equipment, and generally improving the functionality of VE3OSH and VE3NAA.

Our annual Sermon on the Mount corn roast and BBQ is coming up on Tuesday, Sep 18, 1800hrs at the repeater site. Mark this on your calendar and please invite an Amateur, or someone who has a passion for radio, to join us that evening. Members are asked to bring some finger foods to compliment the corn and BBQ, such as chips, veggies, fruit, etc. The only thing we ask visitors to bring is a lawn chair. Also, if you have something that you would like to do a "show and tell" about please bring it along. Let me know ahead of time that you are bringing something to show so I know how to structure the evening announcements. It doesn't even have to be radio related just something unique. I remember in the past that some fellows brought telescopes, homemade boats and other fascinating items.

With the prompting (or maybe prodding) and support of **Steve VA3TPS** and **Vic VE3JAR** I have made my way into digital operation on HF with the FT8 mode. Now, some would say that this mode is quite boring and all you do is exchange grid location and signal report. However, I am quite enjoying it as each station I work I look up on QRZ, read their bio if they have posted one and sometimes drop them a quick email. Ie - one fellow I worked in Goodlettsville, TN (Nashville) lives just a few blocks away from my sister. Another amateur in Ooltewah, TN (Chattanooga) lives on a road that I travel on frequently when visiting the in-laws. I have probably passed his house fifty times in our trips down south. He is a retired gentleman who just recently moved to the area to be near his children. After a few emails back and forth I now have a standing invitation to drop in, have a coffee, and play radio anytime I am down. This is the nice thing about Amateur Radio - it seems to draw a following that are very open to meeting new people and striking up new friendships as if you have known each other all your life. If it was not for this basic digital mode I would probably have never stumbled across these two gentlemen. Now, if I can only hook up with the fellow that has his ham shack in an abandoned fire tower on his property that lives just a couple miles from the in-laws. Have driven by a few times but no one was home.

On the topic of QRZ.com I would encourage you to take a few minutes to sign up, it's free, and setup your bio so others can learn a bit about you when they look up your call. It does not have to be all that long but other hams really appreciate a few tidbits of info other than just your call sign and address when looking you up. Admittedly, mine is a bit long but I was bored one night, the bands were slow, so I had lots of time to work on mine. It is quite easy to make a nice looking page and if anyone needs help I would be glad to offer up some assistance at Tim's on Wednesday nights. Just bring your laptop.

I was able to acquire a few 12v 5.0AH batteries. These would make great portable backup power units for handhelds and low draw radios. I will have some at the BBQ if you would like one or more. The only thing I am asking for is a \$5 per battery donation to the club.

Congratulations are in order as **Larry Whitney** wrote and passed his Amateur Radio test this week! It will be great to be able to chat with Larry on the air once his call arrives.

We hope to see everyone at the Sermon on the Mount on Tuesday evening!

73 de Laird VE3LKS